

## Components

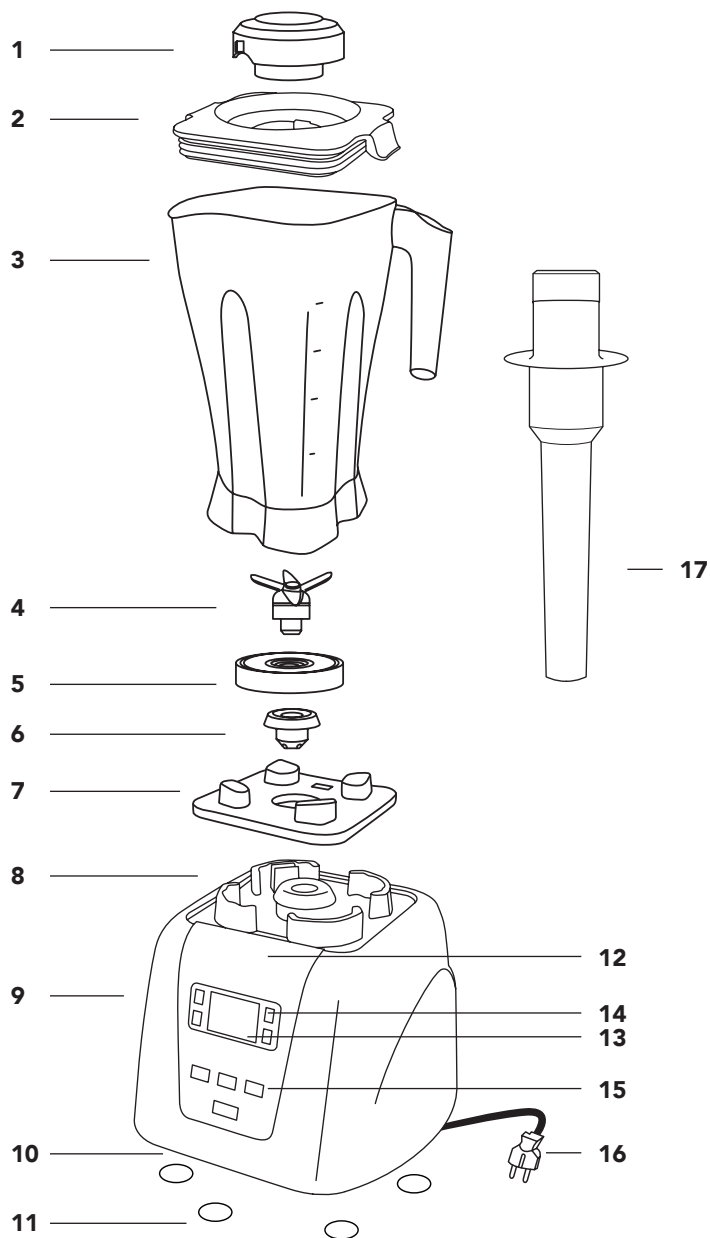

### Components

1	Measuring beaker
2	Lid
3	mix container
4	Stainless steel blades
5	Blade mount
6	Motor coupling
7	Damping mat
8	Sensor for mixing container
9	Motor block
10	Base plate
11	Anti-slip base
12	Control Panel
13	LC Display with runtime
14	Speed and time setting
15	Function buttons
16	Power cable
17	Tamper

## Contents

COMPONENT OVERVIEW .....	1
INTRODUCTION.....	4
INFORMATION ABOUT THIS USER MANUAL .....	5
SAFETY FEATURES.....	5
SAFETY MEASURES.....	6
OPERATING GUIDELINES.....	8
UNPACKING, SCOPE OF DELIVERY AND START-UP.....	9
REQUIREMENTS OF THE INSTALLATION LOCATION .....	10
ELECTRICAL CONNECTION.....	10
OVERVIEW CONTROL ELEMENT.....	11
DESCRIPTION OF THE BUTTONS.....	12
OPERATION <i>piano</i> .....	13
AUTOMATIC PROGRAMME "GREEN SMOOTHIES" .....	14
PROGRAMME DESCRIPTION .....	15
OPERATION <i>piano</i> IN MANUAL MODE.....	16
OPERATION OF THE TAMPER <b>TM</b> .....	17
MEASURING BEAKER, LID AND SILICONE SEAL.....	18
SAFETY INSTRUCTIONS FOR CLEANING .....	18
CLEANING OF THE MIXING CONTAINER (INC. LID), THE MOTOR BLOCK AND THE TAMPER .....	19
NOTES ABOUT GENERAL PREPARATION.....	20
RECIPES TO TRY - GREEN SMOOTHIES .....	22
RECIPES TO TRY - GREEN SAUCE, TOMATO SAUCE AND HUMMUS.....	23
RECIPES TO TRY - TOMATO; ASPARAGUS AND CAULIFLOWER SOUP .....	24

## Contents

RECIPES TO TRY - CASHEW, ALMOND PUREE .....	25
RECIPES TO TRY - APRICOT PUDDING, LEMON CRÈME AND NUT PUDDING .....	26
RECIPES TO TRY- CASHEW, ALMOND AND HEMP MILK .....	27
RECIPES TO TRY - TOMATO, PEANUT AND ZUCCHINI DRESSING .....	28
RECIPES TO TRY - ICE CREAM RECIPES .....	29
RECIPES TO TRY - FRUIT SMOOTHIES.....	30
RECIPES TO TRY - SOY AND SESAME MILK.....	31
TECHNICAL DATA <i>piano</i> .....	32
DISPOSAL GUIDELINES .....	33
DISPOSAL OF USED BATTERIES.....	34
bianco di puro CONTACTS AND bianco di puro CUSTOMER SERVICE	
INDEX .....	35
WARRANTY REGULATIONS.....	36



## Introduction

Dear Customer

great that you have decided to take care of your health. The **piano** helps you with this! You have bought an acknowledged quality product, and we thank you for your purchase.



The green smoothies are the perfect way for healthy nutrition. They deliver highly concentrated vital materials in their most natural style. These are many times more concentrated than in conventionally prepared food.

With the piano they are prepared in no time, taste delicious and supply you with essential nutrients to master the daily challenges.

True to the motto: **„You are what you eat!“**

*We now hope you enjoy your new path to healthy nutrition.*

## Information about this User Manual

This user manual is part of your piano and provides important information for start-up, safety, proper use as well as maintenance of your high performance mixer.

**The user manual must always be available with the device. It must be read by every user who is engaged in the use, cleaning and maintenance of your piano.**

## Safety features

Your piano has 3 safety features to prevent damage to the device and third parties.

### Overheating protection

The motor of your piano is equipped with a temperature control. If during the operation of the mixer the blades rotate too slowly, due to too solid food or not enough liquid, there is the danger of overheating and the motor is switched off. Disconnect the power plug and let your piano cool down in a well ventilated spot for about 45 minutes, afterwards you can continue using your piano as usual.

### Overload protection

The motor coupling is equipped with a predetermined breaking point. This protects the motor, if the blades in the mixing container cannot rotate because of a blockage (e.g. overlooked objects such as spoons etc.) This predetermined breaking point can be replaced by our bianco di puro customer service.

### Sensor for mixing container

The sensor for the mixing container (image [8], page 1) recognizes, if it was put on properly. If the mixing container was not put on the motor block properly, your piano cannot be switched on. Never bypass the sensor, to prevent damage to the device and third parties.

## Safety Precautions

Please observe the following safety precautions for the safe use of the device:

- Check your **piano** before the first use for visible damage of the housing and power cable inc. power plug. Do not operate a damaged device.
- In case of damage to the power cable, the device must not be operated.
- If water or another fluid has entered the motor base, contact your bianco di puro customer service soon. Disconnect the power cable from the power socket and do not use the device anymore.
- Never put the power cable inc. power plug in water or other fluids. Never wipe the power plug with a wet or moist cloth. Never touch the power plug with wet or moist hands.
- In case of damage to the power supply cord, it must be replaced only by the manufacturer or a service agent to avoid a hazard.
- Repairs within the warranty period must only be carried out by the bianco di puro customer service. Incorrect repairs can lead to considerable hazards for the user, additionally the warranty is voided.
- Defective components must only be replaced with original spare parts. Only original spare parts ensure that the safety requirements are fulfilled.
- Never reach into the mixing container with your hands, since considerable injuries can result.
- Operate your **piano** with the supplied mixing container or a container from the bianco di puro product range.
- Fill the mixing container only up to the maximum level (see marking).
- Children and frail persons must always be supervised by a person responsible for their safety, when using the **piano**.
- Always store the device and the mixing container in a place inaccessible to children.
- Always disconnect the power cord by pulling the plug from the power socket, not by pulling the power cord.
- Make sure that the power cord is not snagged anywhere, so the unit does not topple over and no person is harmed.
- Operate the device only with a filled mix container.
- Do not operate the device in direct sunlight or near other heat sources.
- Make sure during operation that the lid inc. seal ring and measuring beaker correctly close the mixing container.
- Always disconnect the power cable when cleaning moving parts.

## Safety Precautions

- Mind the blades during cleaning, since they can cause injuries.
- Do not try to dismantle the blades from the mixing container, since they are fixed to the container.
- Never leave the device without supervision during operation.
- Do not touch the drive coupling at the motor block directly and the bottom of the mixing container after a mixing operation to avoid injuries or burns.
- This appliance shall not be used by children.
- Appliances can be used by persons with reduced physical, sensory or mental capabilities or lack of experience and knowledge if they have been given supervision or instruction concerning use of the appliance in a safe way and if they understand the hazards involved.
- Children shall not play with the appliance.



## Operating Notes

- **If you want to prepare sauces or soups, add the ingredients depending on the degree of hardness in 2 to 3 steps to the mixing container.** The amount should not be too small, but also not too much. Too many ingredients in one process can lead to overheating and automatic shut-down of the motor. Wait in that case until the device cools down (see image 5).
- Always keep the lid of the mixing container closed during the operation of your piano. This avoids any scalding or splashes of hot foods.
- Never during operation reach into the mixing container with your hands to avoid injuries.
- Never put objects into the mixing container during the operation, otherwise the blade and other parts of the device could be destroyed. The exception is the supplied plunger, which is so designed that it cannot contact the blades. **Here it is important that it is only inserted through the lid opening** (image [2], page 1). On page 18 you find the description of the tamper.
- If you want to prepare hot drinks, rice milk or warm soups, take special care that the lid inc. measuring beaker closes the mixing container properly and your **piano** is set up safely. It is advisable to first start at low speed and to increase it gradually. Alternatively, you can use the pulse mode or one of the automatic programmes (warm soup; see page 16 f.).
- If the chosen programme or the manual mode is finished, wait with the removal of the mixing container until the blades are not moving/turning, otherwise the coupling can be damaged.
- An intensive smell can occur due to overloading. Reduce the filling quantity and continue the preparation.
- If a singed smell appears from the motor block, stop the device immediately and disconnect the power supply. The smell can result from abrasion of the rubber mount of the coupling, if it was not mounted properly. Please contact in this case your bianco di puro customer service immediately.
- During preparation of sticky ingredients, such as dough, it can happen that the motor and blades turn idly. This is due to an air bubble that has formed in the ingredients. Stop the programme and remove only the measuring beaker. You can remove the air bubble through the opening with the included tamper. Replace the measuring beaker and continue the preparation.



## Unpacking, scope of delivery

Please proceed as follows to unpack your piano:

- Remove the tamper and all accessories from the box.
- Remove all packaging from the mixer and accessories.
- Keep, if possible, the packaging during the warranty period, to be able to safely and properly package the device in a warranty case.

### Information about the labels on the unit and the tamper

- Please do not remove any labels, since they are applied for safety reasons and are required for any warranty claims.
- Please do not remove the sticker on the handle of the tamper. It depicts the safe use of the tamper.

## Contents

Your mixer is delivered with the following components:

- Motor block *piano*
- 2 litre container for moist ingredients (mixing container)
- lid with integrated measuring beaker
- Tamper *TM*
- this user manual

## Start-up

### **Attention:**

- During the start-up of the device personal injury or property damage can occur.
- Observe the safety instructions on page 6 ff.
- Packing materials must not be used to play with, because there is danger of suffocation.
- Make sure before mixing that the silicone seal is mounted properly in the lid and the measuring beaker is fitted.
- Make sure before mixing that the mixing container is closed with the container lid.

## Requirements of the Installation Location

**For the safe and faultless operation of your piano the installation location must fulfil the following conditions:**

- The motor block must be placed on a level, flat, solid and non-slip surface that ensures the load capacity.
- Make sure that the device cannot fall over,
- Do not place a cloth under the motor block.
- Choose the installation location so that children cannot play with the mixer or reach into it and cannot pull the power cord of the motor block.
- Set-up the mixer only in the interior and do not operate it outside.

## Electrical Connection

**For a safe and faultless operation of the device, the following points for the electrical connection must be observed.**

- Before connecting, compare the technical data of your mixer, voltage and frequency 220 - 240 Volts, 50 - 60 Hz, with your power supply. These data must match, so the device is not damaged. Ask you electronics expert in case of uncertainty.
- The electrical safety can only be ensured, if the motor block is connected to a properly installed protective earth system.
- The manufacturer takes to responsibility for damages caused by a missing or disconnected protective earth.
- Make sure that the power cable is undamaged and does not pass over hot surfaces or sharp edges.
- The power cable must not be pulled tight or under tension.
- Make sure that the power plug is properly inserted into the power socket. A loose power plug can lead to overheating of the device or to electrocution.

## Summary Control Element

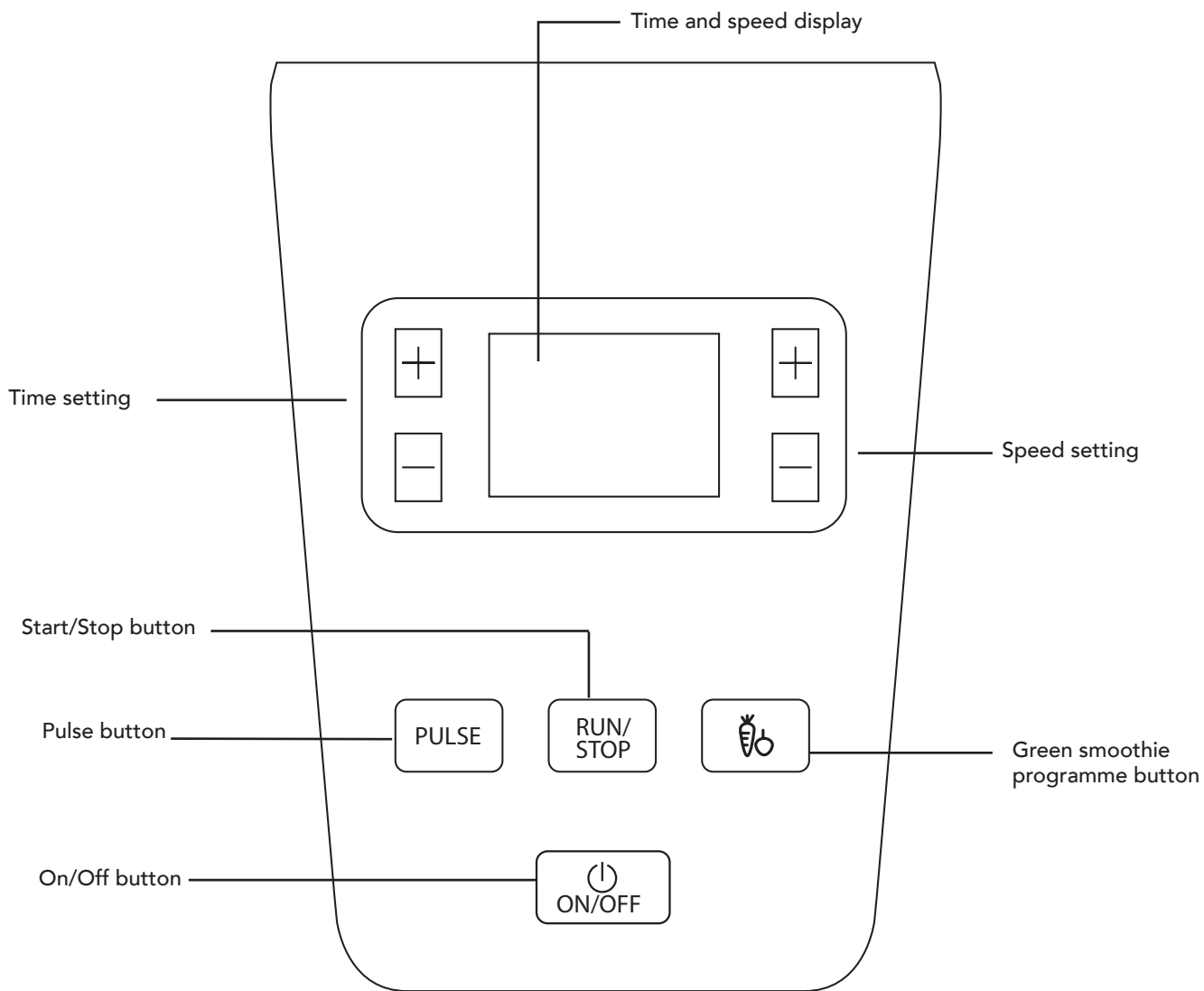

## Description of the Buttons

### **On/Off button**

With this button you activate the standby mode or put the device in energy saving mode.

### **Run/Stop button**

With this button you start the manual mode. With this button the manual mode as well as the automatic programme can be ended prematurely.

### **Pulse button**

With this button you start the pulse mode. Press and hold this button, so the motor works at the highest speed level (level 8) until the button is released. The elapsed time is displayed in seconds.

### **Button time + / -**

With these buttons you can change the runtime settings (1-10 minutes) for the operation in manual mode.

### **Button speed + / -**

With these buttons you can change the speed settings (level 1 to 8) for the operation in manual mode.

### **Programme button green smoothies**

Your piano is equipped with a green smoothie programme. By pressing the programme button "green smoothie", the automatic programme starts immediately.

## Operation piano

Connect your piano to a power socket with the correct electric specifications. You can find them on the rating plate on the back of the device and in the chapter "Technical Data" on page 32. Make sure that the power plug is properly inserted into the power socket.

### Switching On

For the operation of your piano it is necessary to place the mixing container correctly on the motor block. Without the attached mixing container your piano cannot be switched on for safety reasons. The On/Off button is continuously lit red when you place the mixing container on the motor block. Your piano is now in the energy saving mode.

### Energy saving mode<sup>1</sup>

In the energy saving mode the On/Off button flashes red. The display and the function buttons are not illuminated. By pressing the On/Off button once, you set the mixer to the energy saving mode.

### Standby Mode

To activate the standby mode, press the On/Off button once. Now the display and the function buttons are illuminated. Now you can use the mixer in manual mode, pulse mode and the automatic programme.

*Your **piano** automatically changes from standby mode to energy saving mode after 3 Minutes of inactivity.*

<sup>1</sup>Power consumption in energy saving mode: < 0.5 Watt

## Programme Button "Green Smoothies"

### Starting the automatic programme

To start a program, your **piano** must be in standby mode. By pressing the programme button "green smoothie", the automatic programme starts immediately. After the end of the programme, your **piano** stops automatically. To end the programme prematurely, press the **RUN/STOP button**.

Symbol	Programme	Programme sequence	Duration	Display
	Green Smoothies	Level 8 for 20 seconds, 2 seconds stop. Level 6 for 10 seconds, 2 seconds stop. Level 8 for 40 seconds, 2 seconds stop. Level 6 for 10 seconds Soft start at start of programme	01:26	Remaining time, speed setting

### Note

Make sure before the start of the automatic programme that the lid inc. silicone seal and measuring beaker is put on properly.

## Programme Description

### **Green smoothies**

Use this programme to prepare green smoothies at the press of a button. This shreds the green leaves optimally.

### **Note**

You can find recipes to try from page 22.



## Operation of the *piano* in manual mode

### Manual Mode

Besides the green smoothies automatic programmes, you can also operate your piano in manual mode. For this you can set the desired speed level - as described on page 12. The runtime is set manually and confirmed by an acknowledgement tone. When you start the manual mode, you can see the remaining runtime on the display.

### Setting the runtime [TIME]

By pressing the plus button [+] on the left side, you increase the runtime in 1 minute steps. The selected runtime is shown on the left side of the display under [TIME] in minutes. With the minus button [-] on the left side the runtime is decreased in 1 minute steps.

### Setting the speed [SPEED]

By pressing the plus button [+] on the right side the speed level is increased step-by-step. The selected speed is shown on the right side of the display below [SPEED]. The speed is decreased step-by-step with the minus button [-] on the right side.

### Speed levels / rotational speed

The speed depends on the chosen speed level.

**You can change the runtime and speed settings during the operation with the plus and minus buttons.**

*Entnehmen Sie den Mixbehälter erst dann, wenn sich die Messer nicht mehr drehen!*



## Operation of the tamper TM

Always insert the tamper only through the opening in the lid of the measuring container into the measuring container (see image 2, page 1). Use only the provided tamper and no other objects to press the mixing content towards the blades. The less water you use, the more you have to work with the tamper. If you use other objects, the device can be damaged irreparably.

### Overview



With the aid of the tamper you can remove any air bubbles, e.g. when preparing dough, in the mixing container, without touching the blades.

## Measuring beaker, lid and silicone seal

Place the measuring beaker (→img. [1], page2) in the opening of the lid (img. [1], page 2) and twist it tight towards the right. Now place the lid firmly on the mixing container. Turn the measuring beaker to the left to take it off, and lift it off the lid.

You can remove the silicone seal from the lid for easy cleaning. Please take care that the silicone seal is placed in the lid after cleaning. Only then the tightness of the lid is ensured.

## Safety Guidelines or Cleaning

This chapter provides important tips for cleaning and maintenance and care of your *piano*.

Please note the **following safety guidelines** before and during cleaning of your *piano*:

- **Pull the power plug from the power socket before cleaning.**
- **Do not open the housing of the device under any circumstances,**
- **If live contacts are touched and the electrical system is changed, this can lead to an electric shock or even death.**
- **Never place the power plug in water for cleaning,**
- **Never clean the power plug with a wet cloth,**
- **Never touch the power plug with wet hands.**

## Cleaning of the mixing containers (inc. lid), the motor block and the tamper

### Cleaning of the mixing container and lid



#### **Careful when cleaning:**

**The blades can cause injuries!**

**The mixing container does not belong in the dishwasher!**

- • The mixing container can be cleaned with a brush or sponge under running water,
- • Do not use aggressive or abrasive cleaning agents or solvents.
- • Clean the mixing container with a mild cleaning agent (detergent) or fill 2 cups of water into the mixing container, add some detergent, close the lid (inc. silicone seal) and press the pulse button several times.
- • Always clean the mixing container directly after each use.
- • The silicone seal of the lid can be removed for easy cleaning. Make sure before mixing that the silicone seal is correctly mounted in the lid again.
- • Please do not turn the mixing container upside down for drying.

**Achten Sie beim Aufsetzen des Mixbehälters auf den Motorblock, dass die Kontakte richtig trocken sind.**

### Cleaning of the Motor Block

- • Always disconnect the power cable before cleaning.
- • Clean the motor block with a soft and slightly moist cloth.
- • Do not use any aggressive cleaning agents or solvents,
- • Never submerge the motor base in water or other fluids (danger of short circuit).
- • Never rinse the motor block under running water (danger of short circuit).

**If water has entered the motor block, disconnect the power plug immediately from the power socket and contact your bianco di puro customer support.**

### Cleaning if the tamper TM

- Clean the tamper under running water after every use.
- Use some detergent, if necessary, and dry the tamper with a soft cloth.

## Question and Answers about the Operation

With the bianco di puro high performance mixer the preparation of many foods is very easy. One adds the ingredients to the mixing container and selects the desired automatic programme. At once you have a yummy dessert, healthy smoothies or a tasty warm soup and many more!

In reality it has been shown that all beginnings are difficult. Therefore, we have listed the most common questions and their answers for you.

### **During preparation your bianco di puro mixer works flawlessly, but then stalls.**

It is possible that larger pieces of the mixture can get stuck in the lower part of the mixing container. Switch the unit off and try to loosen the large pieces with the tamper. Sometimes only an air bubble forms, which can also be removed with the tamper. If necessary, add more water.

### **During mixing some of the ingredients are pushed against the mixing container and adhere there. The blades do not engage.**

This mainly happens, if smaller amounts are processed as well as during the preparation of almond mousse and other nut mousses. This can be remedied, if the mixture is pushed towards the blades with the tamper, while the device is switched off. Adding of fluid (oil) ensures that the mixture stays at the bottom of the mixing container and can be processed by the blades. Use a lower speed level for this.

### **The mixer stalls and then gives up completely.**

Your bianco di puro high performance mixer is equipped with an overheating protection that makes sure the device does not overheat. Take a frequent break, so that it can cool down. If the overheating protection is tripped, wait for 45 minutes. After that your bianco di puro high performance mixer is ready for use as usual.

## Question and Answers about the Operation

**Almonds, nuts sunflower seeds and seeds are crushed in the mixing container, but there is not creamy mousse.**

Add a neutral cooking oil with a table spoon until the blades engage again and a creamy texture develops. It is often helpful to press the nut mixture towards the blades with the tamper.

Due to friction the temperature in the mixing container rises during the longer preparation of nut mouse. For the puree to meet the criteria of raw fruit and vegetables and no trans fats being formed, one should make sure that the mixture in the mixing container is not heated beyond 42 °C. With a few short breaks the puree as well as the motor can be cooled, if necessary.



## Recipes to try - green smoothies

### Sweet Apple Smoothie

You need:

- 1 ripe banana
- 2 hands of baby spinach
- green leaves of a carrot
- 2 sweet apple
- 4 kohlrabi leaves
- 500 ml fresh water

#### **Preparation**

Peel the banana, quarter the apple and remove only stalk and blossom roots, the seeds can be used. Wash the baby spinach briefly. Now put all ingredients to the mixing container and add the water. Start the programme „green smoothie“. Finished.

Enjoy!

### Green Power Smoothie

You need:

- 1 banana
- 1 apple or mango without core
- 1 handful chard or leaf spinach
- ½ tsp. oil (coconut oil)
- 100 ml apple juice
- 100 ml fresh water

#### **Preparation**

Peel the banana, quarter the apple and remove only stalk and blossom roots, the seeds can be used. Wash the baby spinach briefly.

Now put all ingredients to the mixing container and add the water. Start the programme „green smoothie“. Finished.

Enjoy!

### Sweet Cherry Smoothie

You need:

- 1 mango
- 14 cherries
- 2 nectarine
- 250 g lamb's lettuce
- ½ bunch parsley
- ½ lemon (peeled)
- 500 ml fresh water

#### **Preparation**

Remove the core of the mango, cherries and nectarine, wash the lamb's lettuce briefly. Remove the skin of the lemon with a potato peeler.

Put all ingredients in the mixing container and start the programme „green smoothie“. Finished.

Enjoy!

***First add the leaves to the mixing container, then the softer ingredients such as bananas and fruit. Then add the harder foods, such as carrots or frozen ingredients (ice cubes or fruits) to the mixing container.***

## Recipes to try - green sauce, tomato sauce and hummus

### Green sauce

You need:

- Some fresh salad leaves
- Celery with green leaves
- 1 tblsp. tomato puree
- 2 tblsp. olive oil
- 2 tblsp. fresh lemon juice
- 2 tblsp. fresh water
- Salt and pepper

### **Preparation**

Put all ingredients in the mixing container. Start the mixer manually at a low level and increase the speed to level 8. You can end the mixing process as soon as the desired texture is reached. Season the green sauce to taste with salt and pepper.

Finished.

This green sauce is wonderful with pancakes, pasta, fresh potatoes and many more.

Enjoy!

### Tomato sauce

You need:

- 7 medium sized tomatoes
- 2 small shallots
- 8 fresh basil leaves
- 1 tsp. agave syrup
- 2 tblsp. olive oil
- fresh parsley, chilli pepper
- Salt and pepper

### **Preparation**

Put all ingredients in the mixing container.

Start the mixer manually at a low level and increase the speed to level 8. You can end the mixing process as soon as the desired texture is reached. Season the tomato sauce to taste with salt and pepper.

Finished.

Enjoy!

### Hummus

You need:

- 250 g chickpeas (in a glass or tin)
- 1 tblsp. Tahin (sesame puree)
- 4 tblsp. olive oil
- Juice of a fresh lemon
- some garlic
- ½ tblsp. cumin
- Salt and pepper

### **Preparation**

Put all ingredients in the mixing container.

Start the mixer manually at a low level and increase the speed to level 8. You can end the mixing process as soon as the desired texture is reached. Season the hummus to taste with salt and pepper.

Finished.

Enjoy!



## Recipes to try - tomato, asparagus and cauliflower soup

### Tomato Soup

You need:

- 500 g tomatoes
- 5-6 dried tomatoes
- 200 ml fresh water
- 1 red paprika
- 2 Oranges
- 60 g cashew nuts
- 2-4 fresh basil leaves
- Sea salt and black pepper

#### **Preparation**

Put the ingredients in the mixing container.

Start the mixer manually at a low level and increase the speed to level 8. You can end the mixing process as soon as the desired texture and temperature is reached.

After the end of the programme you can season the tomato soup to taste with some sea salt and black pepper.

1-2 tblsp. oil finish the taste

Finished.

Enjoy!

### Asparagus Soup

You need:

- 300 g peeled white asparagus
- 60 g almonds
- 1 small spring onion
- 1/2 banana (without peel)
- 250 ml fresh water
- Juice of half a lemon
- 1 tsp. zest of an untreated lemon
- Sea salt
- Freshly ground white pepper
- 4 tblsp. cress

#### **Preparation**

Put the ingredients in the mixing container.

Start the mixer manually at a low level and increase the speed to level 8. You can end the mixing process as soon as the desired texture and temperature is reached.

Season to taste with salt and pepper and some cress before serving.

1-2 tblsp. oil finishes the taste.

Finished.

Enjoy!

### Cauliflower Soup

You need:

- ½ cauliflower
- 1 small spring onion
- 1 garlic clove
- 300 ml fresh water
- 1 ripe avocado
- (without core and skin)
- 3 tblsp. agave syrup
- 3 tblsp. chives
- Sea salt
- Freshly ground white pepper

#### **Preparation**

Peel the spring onion and garlic, chop the cauliflower roughly.

If you sauté the onions and the garlic first, the strong taste of these ingredients is diminished.

Put the ingredients in the bianco di puro mixing container.

Start the mixer manually at a low level and increase the speed to level 8. You can end the mixing process as soon as the desired texture

and temperature is reached.

Stir in the chives and season with salt and pepper.

1-2 tblsp. oil finishes the taste.

Enjoy!



## Recipes to try - cashew, almond puree

### Cashew puree

You need:

- 400 g cashew nuts
- 4 tbsp. (sunflower or safflower oil)

### **Preparation**

Fill the cashew nuts with the oil into the mixing container and mix in manual mod at a low level

Afterwards mix manually until a fine paste develops. This can take some time.

Enjoy!

### Almond puree

You need:

- 400 g almonds
- 4 tbsp. (almond or safflower oil)

### **Preparation**

Fill the almonds with the oil into the mixing container and mix in manual mod at a low level

Afterwards mix manually until a fine paste develops. This can take some time.

Enjoy!

„During the preparation of nut purees you must continue to push the nuts onto the blades with the bianco di puro tamper. **During this process the temperature can increase. With a few short breaks the puree as well as the device can be cooled, if necessary.**

(In case of overheating the mixer switches itself of. After about 45 minutes it is ready for use again).

If the nuts are not ground finely enough and large pieces remain, add some extra oil.“

**Tip:** *The various types of nuts should be soaked in fresh water 12 hours before the preparation. Please don't process the used water.*

**With these recipes you must use the tamper TM.  
Always hold the mixing container with your free hand when using the tamper.**



## Recipes to try - apricot pudding, lemon crème and nut pudding

### **Apricot pudding**

You need:

- 400 g apricots(pitted)
- 1 large banana
- 50 ml plant milk
- 3 tblsp. cane sugar
- 1 tblsp. fresh lemon juice
- 1 tsp. locust bean gum
- 2 tblsp. flaked almond
- 2 leaves lemon balm

#### **Preparation**

Add the bananas, apricots, plant milk, sugar and the lemon juice into the mixing container, mix the ingredients in manual mode at level 5 for 10 seconds. Continue to mix afterwards at level 8 for 20 seconds.

Now add the locust bean gum and mix shortly with the pulse button.

Let the pudding cool down well in the refrigerator. Before serving

Enjoy!

### **Lemon crème**

You need:

- 250 g cashew nuts
- 1 tsp. zest of an untreated lemon
- juice of one lemon
- 100 ml fresh water
- 5 tblsp. agave syrup

#### **Preparation**

Put all ingredients into the mixing container

Press the pulse button quickly 5 times and afterwards manually for about 45 sec at level 8, to mix the ingredients.

Let the lemon crème cool down well in the refrigerator.

Enjoy!

### **Nut pudding**

You need:

- 100 g walnuts
- 100 g hazelnuts
- 100 g almonds
- 2 large bananas
- 300 ml nut milk
- 4 tblsp. cane sugar
- 1 pinch of sea salt
- 2 TL ground cinnamon
- some ground bourbon vanilla

#### **Preparation**

Let the nuts soak in fresh water 12 hours before the preparation. (Please don't process the used water). Add the nuts to the mixing container and crush in manual mode.

Peel the bananas and add to the nut flour with the other ingredients.

Now start the manual mode at level 2 and increase to level 8 after a short time so the ingredients are mixed.

Fill the finished nut pudding into a bowl. Let the pudding cool down well in the refrigerator.

Enjoy!

## Recipes to try- cashew, almond and hemp milk

### Cashew milk

You need:

- 100 g cashew nuts
- 750 ml fresh water
- Salt and some sweetener

#### **Preparation**

Fill the cashew nuts and fresh water in the mixing container. Now start the manual mode at level 1 and increase after about 5 seconds to level 8, mix the ingredients for 1 minute. Season the cashew milk to taste with some sweetener and salt. Finished.

Enjoy!

### Almond milk

You need:

- 100 g peeled almonds
- 500 ml water
- some sweetener
- Pinch of salt

#### **Preparation**

Put the ingredients in the mixing container. Now start the manual mode at level 1 and increase after about 5 seconds to level 8, mix the ingredients for 1 minute. Season the almond milk to taste with some sweetener and salt. Finished.

Enjoy!

#### **Tip:**

If you filter the almond milk after mixing, it becomes milder and lighter.

### Hemp milk

You need:

- 85 g hemp seeds
- 500 ml fresh water or
- 50 g peeled hemp seeds
- 750 ml fresh water

#### **Preparation**

Put the hemsps seeds and the water into the mixing container. Now start the manual mode at level 1 and increase after about 5 seconds to level 8, mix the ingredients for 1 minute. Finished.

Enjoy!

#### **Tip:**

If you filter the hemp milk after mixing, it becomes milder and lighter.



## Recipes to try - tomato, peanut and zucchini dressing

### Tomato dressing

You need:

- 2 tomatoes
- 3 apricots
- 1 small spring onion
- 2 tblsp. freshly squeezed lemon juice
- 1 dried chilli
- 1 tsp. sugar

#### **Preparation**

Remove the apricot kernels

Put all the ingredients into the mixing container.

Now start the manual mode at level 1 and increase after about 5 seconds to level 8, mix the ingredients for 1 minute.

Season the dressing to taste with some salt.

Finished.

Enjoy!

### Peanut dressing

You need:

- 100 g peanuts
- 1/2 red pepperoni
- 5 stems of parsley
- juice of half a lemon
- some lemon zest
- 100 ml nut milk
- 1 tsp. agave syrup
- Sea salt

#### **Preparation**

Remove the core of the pepperoni, pluck the parsley from the stems.

Put all ingredients into the mixing container

Now start the manual mode at level 1 and increase after about 5 seconds to level 8, mix the ingredients for 1 minute.

Season with salt. Finished.

Enjoy!

### Zucchini dressing

You need:

- 1 small zucchini
- 1 garlic clove
- 75 g pine nuts
- 4 leaves Basil
- 70 ml water
- 2 tblsp. lemon juice
- Sea salt
- Freshly ground white pepper

#### **Preparation**

Peel the zucchini and garlic

Put all ingredients into the mixing container

Now start the manual mode at level 1 and increase after about 5 seconds to level 8, mix the ingredients for 1 minute.

Add salt and pepper to taste. Finished.

Enjoy!

## Recipes to try - ice cream recipes

### Coconut-raspberry ice cream

You need:

- 200 g frozen raspberries
- 100 g cashew nuts
- 100 - 200 ml solid coconut milk

#### **Preparation**

Put all ingredients in the mixing container, close the lid without the measuring beaker and insert the supplied tamper in the opening. Start the manual mode for about 45 sec. at level 8.

Use the tamper TM during the process to press the frozen fruit continuously onto the blades.

You can add some stevia or agave syrup afterwards, if the "ice cream" is not sweet enough.  
Finished.

Enjoy!

### Pistachio ice cream

You need:

- 3 small bananas
- 1 avocado
- 50 g peeled green pistachios
- 3 dried dates
- ½ vanilla pod
- 2 tblsp. cashew puree
- 50 ml cold nut milk
- 1 tblsp. pumpkin seed oil

#### **Preparation**

Peel the bananas, remove the avocado kernel and peel. Freeze these in small pieces.

Put the remaining ingredients with the frozen bananas and avocados into the mixing container. Close it with the lid without the measuring beaker and insert the supplied tamper through the opening. Start the manual mode for about 45 sec. at level 8.

Finished.

Enjoy!

### Chocolate ice cream

You need:

- 3 bananas
- 6 dried dates without kernel
- 3 tblsp. walnuts
- 2 tblsp. cocoa powder
- 100 ml nut milk
- 2 tblsp. almond puree
- 3 tblsp. chopped almonds

#### **Preparation**

Peel the bananas and freeze in small pieces. Chop the almonds roughly by pressing the pulse button several times and fill into a dish.

Now fill the frozen banana pieces and the remaining ingredients into the mixing container.

Close it with the lid without the measuring beaker and insert the supplied tamper through the opening. Start the manual mode for about 45 sec. at level 8.

Add the chopped almonds to the creamy ice cream.  
Finished.

Enjoy!

**With these recipes you must use the tamper TM  
Always hold the mixing container with one hand when using the tamper.**



## Recipes to try - fruit smoothies

### Fruit smoothie

Sie benötigen:

- 1/2 mango (without kernel)
- ½ grapefruit
- ½ orange
- 1 medlar
- ½ pomegranate
- 500 ml fresh water

#### **Preparation**

Use only the kernels of the pomegranate. Peel the skin of the orange with a potato peeler.

Put the ingredients in the mixing container.

Start the mixer manually at a low level and increase the speed to level 8. You can end the mixing process as soon as the desired texture is reached.

Finished.

Enjoy!

### Pina Colada smoothie

Sie benötigen:

- 200 g pineapple
- 200 g raw coconut puree
- 100 ml fresh water

#### **Preparation**

Remove the skin of the pineapple and cut the pineapple in small pieces.

Put this and the other ingredients into the mixing container.

Start the mixer manually at a low level and increase the speed to level 8. You can end the mixing process as soon as the desired texture is reached.

Finished.

Enjoy!

### Cold chocolate smoothie

Sie benötigen:

- 3 bananas
- 500 ml nut milk
- 5 tblsp. agave syrup
- 5 tblsp. cocoa powder
- 2 tblsp. cocoa nibs( if at hand )
- 1 tsp. ground bourbon vanilla

#### **Preparation**

Peel the bananas and freeze in small pieces.

Put this and the other ingredients into the mixing container. Start the mixer manually at a low level and increase the speed to level 8. You can end the mixing process as soon as the desired texture is reached.

Finished.

Enjoy!

**If you want to enjoy your fruit smoothie cold, reduce the amount of fresh water and add some ice cubes.**

## Recipes to try - soy and sesame milk

### Soy milk

You need:

- 150 g soy beans
- 1 litre fresh water
- Sweetener (e.g. dates without stones)

### **Preparation**

Cook the soy beans for one hour.

Now fill the soy beans and fresh water in the mixing container.

Start the mixer manually at a low level and increase the speed to level 8 for about 5 minutes.

Season afterwards with some sweetener.

Finished.

Enjoy!

### Sesame milk

You need:

- 100 g peeled sesame
- 1-2 dried dates without stones
- 1 banana (without skin)
- Juice of one orange
- 2 tblsp. lemon juice
- 600 ml fresh water

### **Preparation**

Put the sesame and the other ingredients into the mixing container. Start the mixer manually at a low level and increase the speed to level 8 for about 5 minutes.

Finished.

Enjoy!

**Tip: After cooking, you can freeze a small supply of soy beans in portions and use as required. It is also possible to use the frozen beans directly.**



## Technical Data

### *piano*

<b>Voltage / frequency</b>	220 - 240 V / 50 - 60 Hz
<b>Power</b>	1,250 Watt
<b>Rotations</b>	3,000 rpm (Level 1) - up to 28,000 rpm (Level 8)
<b>Electrical power</b>	6.8 Ampere
<b>Mixing container</b>	2 litres, Tritan plastic, BPA free
<b>Max. temperature</b>	125 °C
<b>Blade type and material</b>	4 stainless steel blades
<b>Control element</b>	Button for 1 automatic programme, On/Off button, buttons for manual speed and time settings, display with speed and runtime and pulse button.
<b>Safety features (see p. 5)</b>	overheating protection, overload protection and sensor for the mixing container.
<b>Device dimensions</b>	(h) 338 mm x (w) 248 mm x (d) 427 mm
<b>Packaging dimensions</b>	(h) 352 mm x (w) 262 mm x (d) 445 mm
<b>Device weight</b>	4.1 kg
<b>Packaging weight</b>	5.48 kg
<b>Certification / Standards</b>	ITS -GS, CE, EMC, CB, LVD, CCC, PAH
<b>Manufacturer's warranty</b>	2 years on the motor block 2 years on the mixing container, 2 years on the tamper
<b>Power consumption in standby</b>	< 0.5 Watt
<b>Type of use</b>	For domestic use, not intended for commercial use.

### Tamper TM

<b>Farbe</b>	Schwarz
<b>Tamper dimension</b>	(h) 300mm x (w) 82 mm
<b>Packaging dimensions</b>	(h) 337 mm x (w) 118 mm x (d) 88 mm
<b>Weight</b>	0.16 kg
<b>Manufacturer's warranty</b>	2 years
<b>Max. temperature</b>	125 °C



## Disposal Note

The packaging protects your mixer from damage during transportation. The packaging materials have been chosen with the consideration of environmental compatibility and disposal aspects and are therefore recyclable.

The return of the packaging to the material cycle reduces the generated waste and saves raw materials. Dispose of not needed packaging materials at the collection facilities of the collection system "Green Point".

**Keep, if possible, the packaging during the warranty period, to be able to properly package the device in a warranty case.**



Device and packaging must be disposed of according to the local regulations for the disposal of electrical waste and packaging materials. If necessary inform yourself at your local waste management company.

Do not dispose of electrical devices in household waste, use the collection facilities of your community. Ask your municipal administration for the sites of the collection facilities. When electrical devices are disposed of without control, dangerous substances can reach the groundwater during corrosion and therefore the food chain as well as poison plants and animals for years.

## bianco di puro contacts bianco di puro customer service

### Contacts

#### **bianco di puro GmbH & Co. KG**

Maarweg 255  
D-50825 Cologne  
Germany

Telephone +49 221 50 80 80-0  
Fax +49 221 50 80 80-10  
Mail [info@biancodipuro.com](mailto:info@biancodipuro.com)

Visit our website at [www.biancodipuro.com](http://www.biancodipuro.com)

### Customer Service

#### **bianco di puro GmbH & Co. KG**

Maarweg 255  
D-50825 Cologne  
Germany

Telephone +49 221 50 80 80-20  
Fax +49 221 50 80 80-10  
Mail [kundenservice@biancodipuro.com](mailto:kundenservice@biancodipuro.com)

## Index

Automatic programme "green smoothies" .....	14
Standby mode.....	13
Switching on your <i>piano</i> .....	13
Energy saving mode .....	13
Speed settings .....	16
Speed levels.....	16
Setting the runtime .....	16
Manual mode .....	16
On/Off button.....	12
Programme button "green smoothies" .....	12
Pulse mode.....	12
Cleaning of the mixing container, the lid and the tamper .....	19
Cleaning of the motor block.....	19
Sensor for mixing container.....	5
Tamper .....	17
PULSE button.....	12
SPEED button +/- .....	12
TIME button +/- .....	12
Overheating protection .....	5
Overload protection .....	5



## bianco di puro Service Centre

**bianco di puro GmbH & Co. KG** Telephone +49 221 50 80 80-20  
Maarweg 255 Fax +49 221 50 80 80-10  
50825 Cologne Mail kundenservice@biancodipuro.com  
Germany Internet www.biancodipuro.com

Please have the purchase date and serial number of the device at hand. The serial number is attached on the bottom of the device.

### Attention

- It is absolutely necessary to read the instructions before use.
- Do not submerge the motor block in water.
- Disconnect the power plug if not in use!
- Attention: Do not open the device, danger of electrocution!

## Warranty Regulations

We supply the following manufacturer's warranty with our bianco di puro high performance mixer:

- 2 years manufacturer's warranty on the motor block
- 2 years manufacturer's warranty on the mixing container
- 2 years manufacturer's warranty on the tamper (except for the battery).

The warranty encompasses material, construction and manufacturing defects of all parts.

The device is certified for domestic use, not intended for commercial use.

If a fault occurs in your bianco di puro high performance mixer within the warranty period despite proper use, it will, at the choice of the manufacturer be repaired or faulty parts replaced free of charge or an equivalent device delivered in exchange.

For this the whole device including all accessories must be cleaned thoroughly, packaged well and sent to the bianco di puro service address. Please note: If the parts of the device have not been cleaned, our service is going to charge cleaning costs, irrespective of the warranty. It is advisable to keep the original packaging for the case of return.

Please always call the customer service first, before you return the device. Sometimes a telephone conversation with our service can solve the problem and save the packaging and shipping. The bianco di puro service team is going to solve your problem in every case as quickly as possible.

If the return of your device is still necessary, please contact our customer service first about the shipping. That way the shipping costs can be minimized.

## The warranty does not encompass

1. Causes are due to processing and manufacturing of the device, i.e. careless damages or falling of the device.
2. Usage and applications differing to the instruction manual, careless treatment, technical changes by the customer.
3. Damage caused by foreign spare parts or repairs by unauthorized companies.

## To process your warranty claim the following information is required:

1. Your name, address, telephone number
2. Serial number and model name
3. Description of the problem
4. Purchase date
5. Seller
6. Copy of the invoice
7. In case of damage during transport: Name of the parcel service and parcel number

## Important

Keep the packaging during the warranty period, to be able to properly package the device in a warranty case.

When you package your bianco di puro high performance juicer, pack all parts in the original package and make sure that you have included all parts. Do not forget to add your address to the outside.